

# PROSTAR MAIN ASSEMBLY

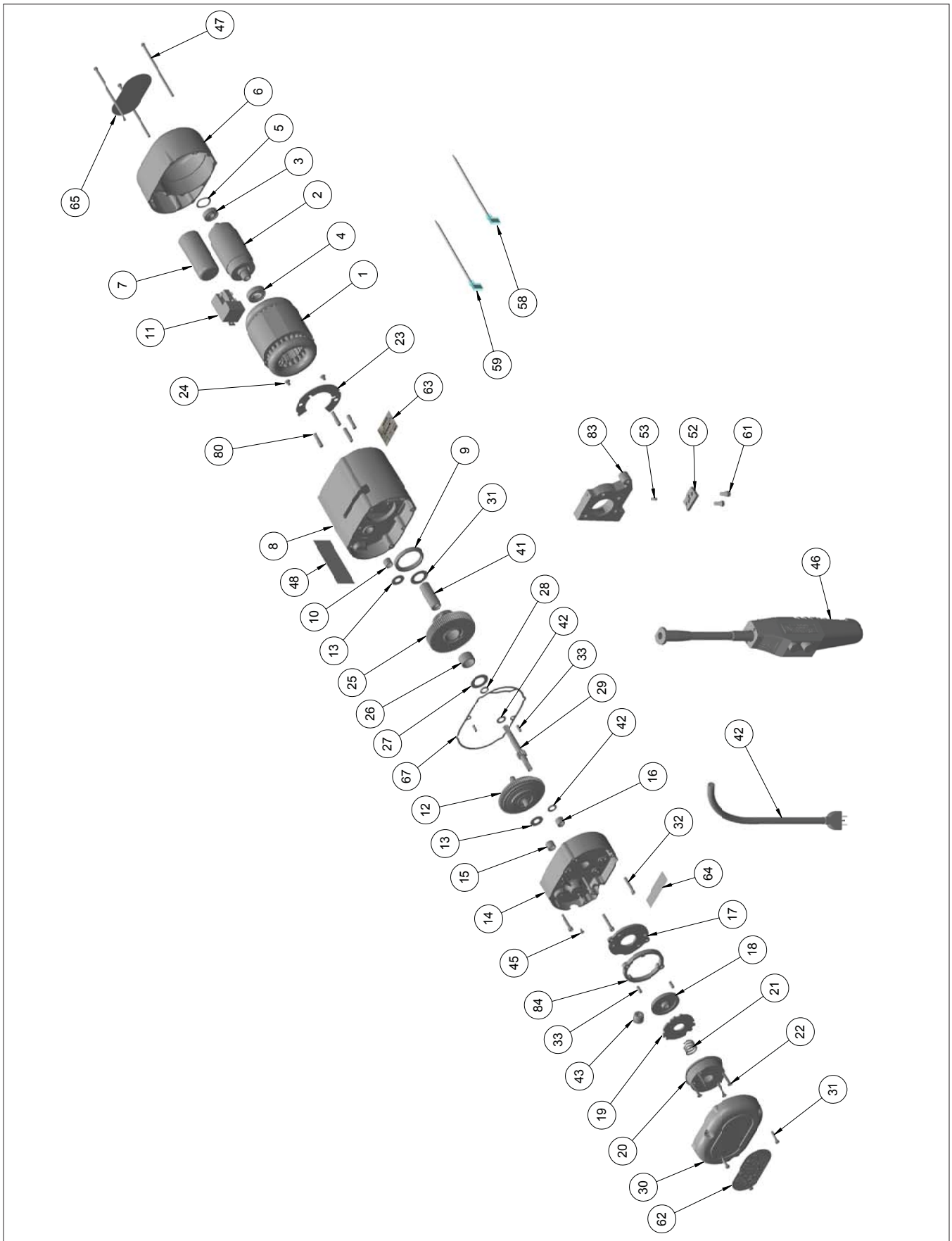

# PROSTAR MAIN ASSEMBLY

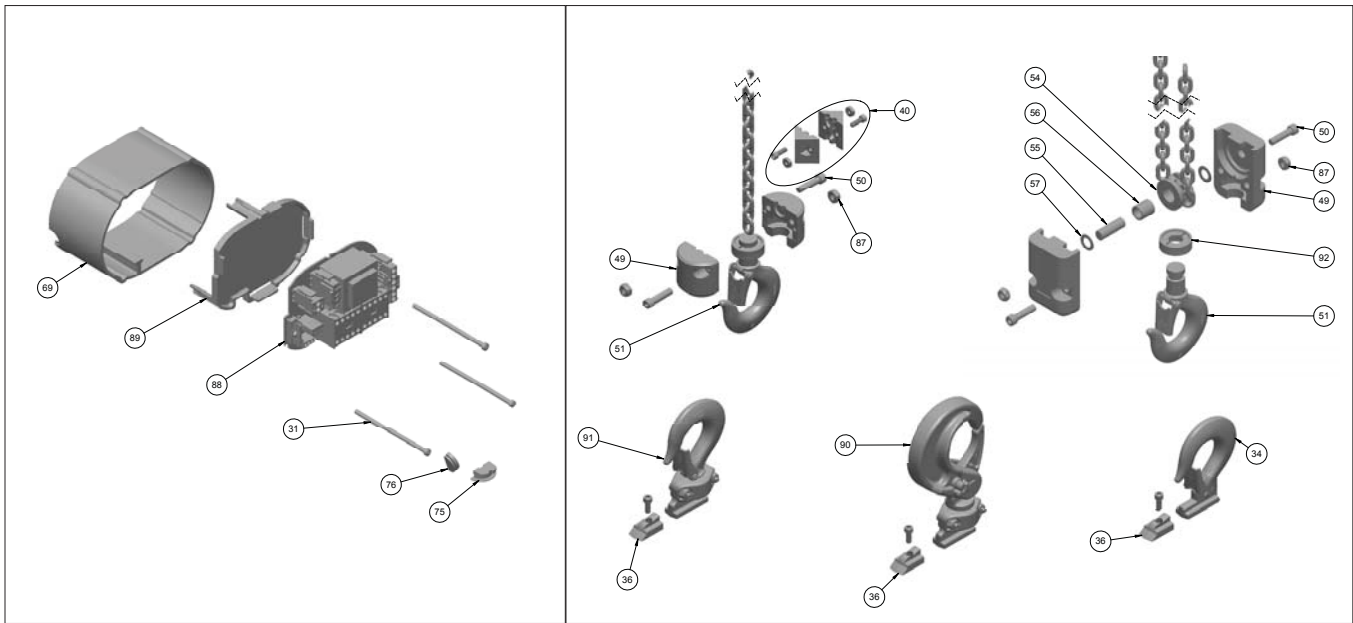
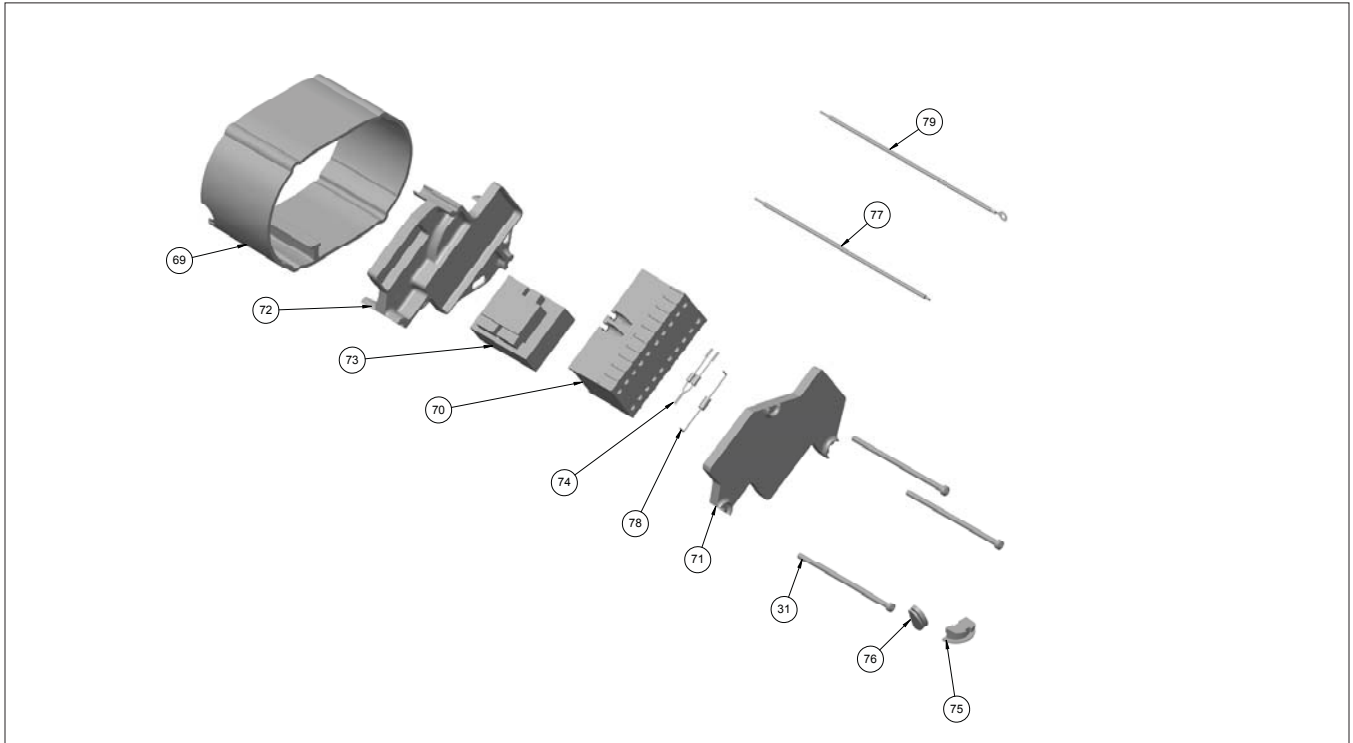

# PROSTAR ELECTRIC HOIST PARTS LIST

ITEM NUMBER	PART NAME	NO. REQ'D	PART NUMBER
1	Stator		
	115-1-50/60 Hoists	1	20707
	220-1-50 Hoists	1	20328
	220-3-50/60 Hoists	1	20329
	380-3-50, 415-3-50 And 460-3-60 hoists	1	20330
	575-3-60 Hoists	1	20344
2	Rotor assembly	1	20651
3	Rotor bearing, outboard	1	88487
4	Rotor bearing, inboard	1	88486
5	Rotor thrust washer	1	20727
6	Motor end cover	1	20321
7	Capacitor		
	115-1-50/60 Hoists	1	20708
	220-1-50 Hoist	1	20785
8	Main frame	1	20353
9	Liftwheel seal	1	20705
10	Protector bearing, main frame side	1	88636
11	Cut-out device		
	115-1-50/60 Hoists	1	20709
	220-1-50/60 Hoists	1	20786
12	Protector assembly		
	6 fpm (1.8mpm), 1,000 lbs. (453kg)	1	20665
	8 fpm (2.4mpm), 500(226kg) & 600 lbs. (272kg)	1	20645
	8 fpm (2.4mpm), 1000 lbs. (453kg)	1	20660
	12 fpm (3.7mpm), 500 lbs.(226kg)	1	20665
	12 fpm(3.7mpm), 600 lbs.(272kg)	1	20638
	12 fpm(3.7mpm), 1000 lbs.(453kg)	1	20662
	13.4 fpm(4.0mpm), 550 lbs.(250kg)	1	20660
	16 fpm(4.9mpm), 250(113kg) & 300 lbs. (136kg)	1	20645
	16 fpm(4.9mpm), 500 lbs.(226kg)	1	20660
	20 fpm(6.1mpm), 500 lbs(226kg)	1	20648
	20 fpm(6.1mpm), 600 lbs.(272kg)	1	20661
	24 fpm(7.3mpm), 250(113kg) & 300 lbs. (136kg)	1	20638
	24 fpm(7.3mpm), 500 lbs.(226kg)	1	20662
	40 fpm(12.2mpm), 250 lbs.(113kg)	1	20648
40 fpm(12.2mpm), 300 lbs.(136kg)	1	20661	
13	Protector thrust washer	2	88640
13	Protector thrust washer	2	88640
14	Gear housing	1	20351
15	Protector bearing - gear housing side	1	88636
16	First pinion bearing	1	88635
17	Brake base plate	1	20724
18	Brake disc	1	20698
19	Brake armature	1	20420

ITEM NUMBER	PART NAME	NO. REQ'D	PART NUMBER
20	Brake field (includes brake coil)		
	115-1-50/60 hoists	1	20659
	220-1-50 hoists		
	220-3-50/60 hoists		
	380-3-50 hoists	1	20658
	415-3-50 hoists		
	460-3-60 hoists		
	575-3-60 Hoists	1	20629
21	Brake spring	1	20887
22	Brake screw	4	920740
23	Pin retainer plate	1	20700
24	Pin retainer plate screw	2	20743
25	Liftwheel and gear assembly		
	6 fpm(1.8mpm), 1,000 lbs. (453kg)	1	20666
	8 fpm (2.4mpm), 500(226kg) & 600 lbs. (272kg)	1	20664
	12 fpm (3.7mpm), 500 lbs.(226kg)	1	20666
	12 fpm(3.7mpm), 600(272kg) & 1000lbs. (453kg)	1	20647
	13.4 fpm(4.0mpm), 550 lbs.(250kg)	1	20664
	16 fpm(4.9mpm), 250(113kg), 300 lbs. (136kg) & 500 lb.(226kg)	1	20664
	20 fpm, 500 & 600(272kg) lbs.	1	20657
	24 fpm, 250, 300 & 500 lbs.	1	20647
	40 fpm, 250 & 300 lbs.	1	20657
26	Liftwheel bearing	2	88637
27	Liftwheel thrust washer	2	88638
28	Liftwheel shaft seal	1	20704
29	First pinion and shaft		
	10 Tooth	1	Contact factory
	12 Tooth	1	
30	Brake end cover	1	20345
31	Brake end cover screw		
	Hoists without contactor	3	920715
	Hoists with contactor	3	20808
32	Gear housing screw	4	920718
33	Frame pin	4	920720
34	Hook	1	20650B
35	Hook latch kit	1	595522
36	Hook retainer kit	1	20712K
37	Chain guide screw (not shown)	1	987859
38	Load chain (specify lift or length required)	-	85988
39	Loose end ring	1	20744
40	Chain stop-sure stop kit	1	20428K
41	Liftwheel shaft	1	20313
42	First pinion thrust washer	2	88639
43	Power cord grommet	1	20779



ITEM NUMBER	PART NAME	NO. REQ'D	PART NUMBER
44	Power cord		
	115-1-50/60 Hoists with contactor		
	220-1-50 Hoists	1	20516
	220-3-50/60, 380-3-50, 415-3-50, 460-3-60 And 575-3-60 hoists	1	20501
45	Power cord ground screw	1	982877
46	Control station and cord assembly (includes control station, cord, warning tag and upper grommet)		
	Black control station for:		
	10 ft. Lift	1	20642
	15 ft. Lift	1	20643
	20 ft lift	1	20644
	For other lifts contact cm		
47	Motor cover screw	1	920719
48	Caution label	1	20758
49	Hook block (single chained)	2	20995
	Hook block (double chained)	2	20739
50	Hook block screw (single chained)	2	82554
	Hook block screw (double chained)	2	920724
51	Hook	1	23030
	Latchlok hook	1	40618
52	Dead end plate, (double chained)	1	20714
53	Dead end pin, (double chained)	1	920720
54	Sheave wheel w/620-164, (double chained)	1	20652
55	Sheave wheel shaft, (double chained)	1	20318
56	Sheave wheel bearing, (double chained)	1	88641
57	Sheave wheel thrust washer, (double chained)	2	88639
58	Jumper (#2)	1	20610
59	Jumper (cap)	1	20609
60	Dead end plate screw, (double chained)	2	73715
61	Dead end plate screw, (double chained)	2	73715
62	Capacity warning label		
	250 lb.(113kg)	1	20762
	300 lb.(136kg)	1	20737
	500 lb.(226kg)	1	20763
	550 lb.(250kg)	1	20509
	600 lb.(272kg)	1	20738
	1,000 lb. (453kg)	1	20884
1,100 lb.	1	20514	
63	I.D. Label	1	Contact factory
64	Warning label	2	24842
65	Prostar label	1	20764
66	Wire nut (not shown, specify no. Req'd)	-	920756
67	Gasket	1	20755
68	Control cord assembly (Includes cord, strain relief and warning tag)		
	For black control station and		
	10 ft. lift	1	20675
	15 ft. lift	1	20676
	20 ft. lift	1	20677
	For other lifts, contact factory		

ITEM NUMBER	PART NAME	NO. REQ'D	PART NUMBER
69	Frame spacer	1	20333B
70	Contactor (includes power jumpers)		
	115 VAC coils	1	20814
	48 VAC coils	1	20787
71	Components board - outboard	1	20777
72	Components board - inboard	1	20778
73	Transformer		
	48 Volt secondary (220/380 primary)	1	20851
	48 Volt secondary (change to 460/60 hz or 380/50Hz primary)	1	20834
	115 Volt secondary (230/460 primary)	1	20831
	115 Volt secondary (575 primary)	1	20876
	48 Volt secondary (575 primary)	1	20866
74	Diode assembly	1	20789
	Diode/tvs assembly	1	20383
75	Control cord plug	1	20780
76	Power cord plug	1	20781
77	Contactor jumper (specify no. Req'd)	-	20332
78	Voltage suppressor		
	230-3-50/60, 380-3-50 and 460-3-60 hoists	1	20861
	575-3-60 Hoists	1	20869
79	Ground jumper	1	20641
80	Chain guide pin	4	20729
81	Chain guide spacer	1	20812
82	Warning label	1	20765
83	Chain guide stripper	1	20622
84	Brake spacer	1	20723
85	Hook block screw lockwasher (double chained)	2	940802
	Hook block screw lockwasher (single chained)	2	983544
86	Warning label	1	24884
87	Hook block screw nut (single chained)	2	82638
88	Printed Circuit Board	1	10001998
89	Printed Circuit Board retainer	1	10001979
90	Swivel latchlok hook	1	10001297
91	Suspension swivel hook	1	10001130
92	Wedge halves	2	10001955
	Wedge ring	1	10001956
	Thin washer	2	10001953
	Bearing	1	10001954